

# Terminal adapter - TMC 7 B2/3 TERM



1022232

<https://www.phoenixcontact.com/us/products/1022232>

Please be informed that the data shown in this PDF document is generated from our Online Catalog. Please find the complete data in the user documentation. Our General Terms of Use for Downloads are valid.

Feeder terminal adapter for TMC 72 or TMC 73 circuit breakers, two- or three-phase bus bars. Rated for 600 V AC/DC 115 A. Wire range 10...1/0 AWG. UL 508 Listed for connection to UL 1077 rated circuit breakers.



## Product Description

Feed-in terminal adapter for TMC 7 two- and three-pos. bus bars

## Commercial Data

|                                      |               |
|--------------------------------------|---------------|
| Item number                          | 1022232       |
| Packing unit                         | 1 pc          |
| Sales Key                            | C30           |
| Product Key                          | CLA126        |
| GTIN                                 | 4055626515908 |
| Weight per Piece (including packing) | 39.53 g       |
| Weight per Piece (excluding packing) | 37 g          |
| Country of origin                    | DE            |

# Terminal adapter - TMC 7 B2/3 TERM



1022232

<https://www.phoenixcontact.com/us/products/1022232>

## Technical Data

### Product properties

|      |         |
|------|---------|
| Type | Adapter |
|------|---------|

### Electrical properties

|                       |              |
|-----------------------|--------------|
| Rated voltage (III/3) | 1000 V AC/DC |
|-----------------------|--------------|

### Connection data

|                        |         |
|------------------------|---------|
| Tightening torque, min | 5.65 Nm |
|------------------------|---------|

### Dimensions

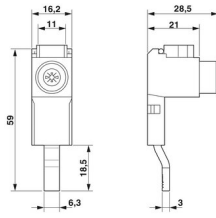
|                     |   |
|---------------------|---|
| Dimensional drawing |  |
| Width               | 16.2 mm   |
| Height              | 28.5 mm   |

# Terminal adapter - TMC 7 B2/3 TERM

1022232

<https://www.phoenixcontact.com/us/products/1022232>



## Drawings

Dimensional drawing

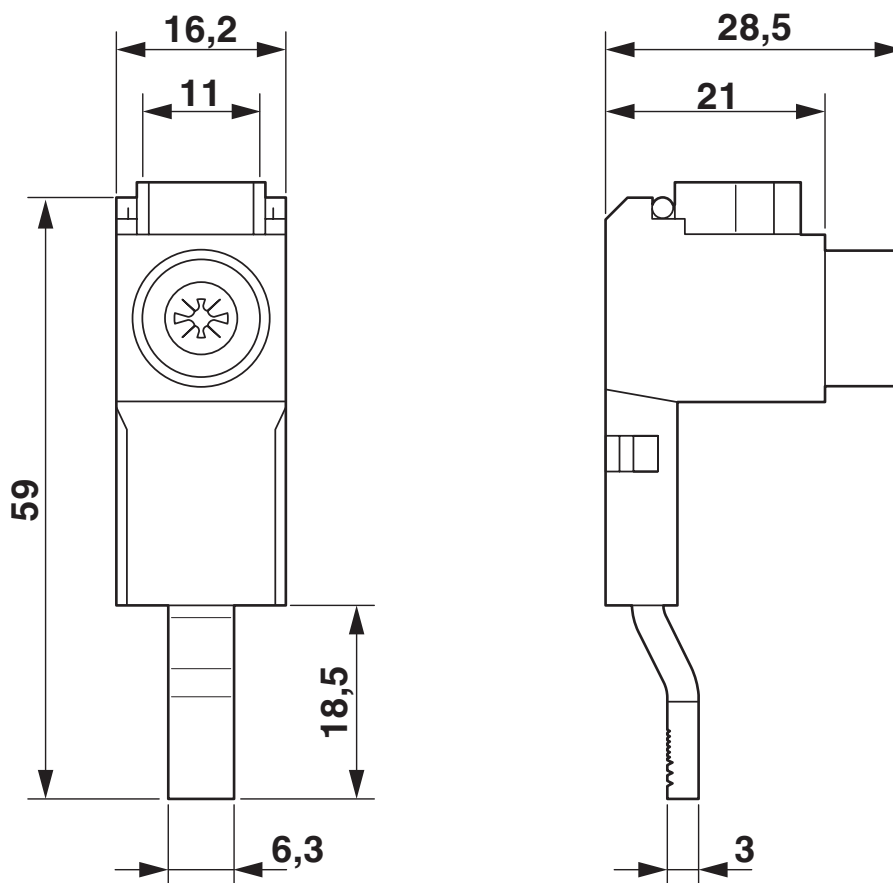

# Terminal adapter - TMC 7 B2/3 TERM



1022232

<https://www.phoenixcontact.com/us/products/1022232>

## Approvals



**UL Listed**

Approval ID: FILE E 123528



**cUL Listed**

Approval ID: FILE E 123528

**cULus Listed**

# Terminal adapter - TMC 7 B2/3 TERM



1022232

<https://www.phoenixcontact.com/us/products/1022232>

## Classifications

### ECLASS

|             |          |
|-------------|----------|
| ECLASS-11.0 | 27144037 |
|-------------|----------|

# Terminal adapter - TMC 7 B2/3 TERM



1022232

<https://www.phoenixcontact.com/us/products/1022232>

## Environmental Product Compliance

|            |                         |
|------------|-------------------------|
| REACH SVHC | Lead 7439-92-1          |
|            | Cadmium oxide 1306-19-0 |

Phoenix Contact 2022 © - all rights reserved  
<https://www.phoenixcontact.com>

Phoenix Contact USA  
586 Fulling Mill Road  
Middletown, PA 17057, United States  
(+717) 944-1300  
[info@phoenixcon.com](mailto:info@phoenixcon.com)